

# **UART/RS232/RS485 Over Powerline Communication Transceiver Module**

## **User Manual**



**LinkSprite Technologies, Inc**

**July, 2008**

**[www.linksprite.com](http://www.linksprite.com)**

## Table of Content

I	Summary .....	3
1	Introduction .....	3
2	Features .....	4
3	Specifications .....	5
4	Applications .....	5
II	Diagram.....	6
1	Functional Diagram.....	6
2	Board Layout.....	6
3	LED.....	7
4	Definition of Pin.....	7
III	Command Interface.....	8
1	Command Mode.....	8
1.1	Enter command mode .....	8
1.2	Exit command mode .....	8
2	Arguments and Responses .....	8
2.1	Arguments and Responses .....	8
2.2	Commands without Arguments.....	9
2.3	Modified arguments .....	9
3	Command List.....	10
IV	Repeater Function .....	13
1	Introduction.....	13
2	Function Setting .....	14
2.1	Start repeater function .....	14
2.2	Turn off repeater function .....	15
2.3	Setting Illustration.....	15
3	Repeater Grade.....	15
V	Logic Address .....	17
1	Logic Address .....	17
2	Address Setting .....	18
VI	Application Illustration .....	20

# I Summary

## 1. Introduction

UART/RS232/RS485 are widely used in industrial control and instrument fields. PLC-UART, PLC-RS232/RS485 transceiver modules from LinkSprite (LinkSprite modules) are transceiver modules designed to send/receive UART/RS232/RS485 data over the powerline network. PLC-RS232/RS485 is designed to transparently move serial data over the powerline network, and achieves the target of replacing RS232/RS485 cables by the ubiquitous powerline network.

LinkSprite modules have the built-in packet-level repeater function. This feature can greatly extend the coverage of the powerline communication.

LinkSprite modules has both physical and logic addresses. In a network, both physical and logic addresses can be used to address different nodes in the network.

## 2 Features

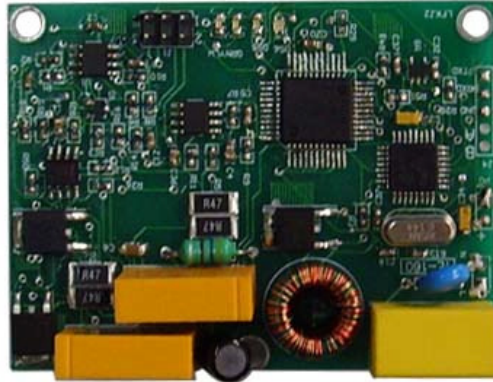

- Fully transparent mode, plug and play coming out of the box without the need to do any programming.
- Built-in error correction codes.
- Built-in repeater function to extend the coverage.
- Physical and logic address
- AT commands used for advanced configuration.
- UART, RS232 interface and RS485 bus
- FSK (Frequency Shift Keying) modulation used in physical layer
- Low power
- RoHS
- Small module size, and easy to be implemented into existing products.

### 3 Specifications

<b>Product name</b>	PLC-UART/RS232/RS485 Transceiver Module
<b>Interface</b>	UART, RS232 or RS485
<b>Operating Voltage</b>	230VAC/50Hz, 110VAC/60Hz
<b>Modulation</b>	FSK (Frequency Shift Keying)
<b>Carrier frequency</b>	262K/144KHz
<b>Error Correction</b>	FEC (Forward Error Correction)
<b>Data rate on Powerline</b>	30Kbps
<b>Maximum packet data length</b>	320bytes
<b>Repeater Hops</b>	3 Hops
<b>Transmission distance</b>	300 feet (no repeater)
<b>Support nodes number</b>	65535
<b>LED</b>	Power Line Activity LED system LED serial port LED

### 4 Applications

- AMR
- Industry manufacture and control
- Safeguard, fire alarm, smoke alarm
- Collect and transmit instrument data
- Safeguard and monitor
- Home automation

## II Diagram

### 1 Functional Diagram

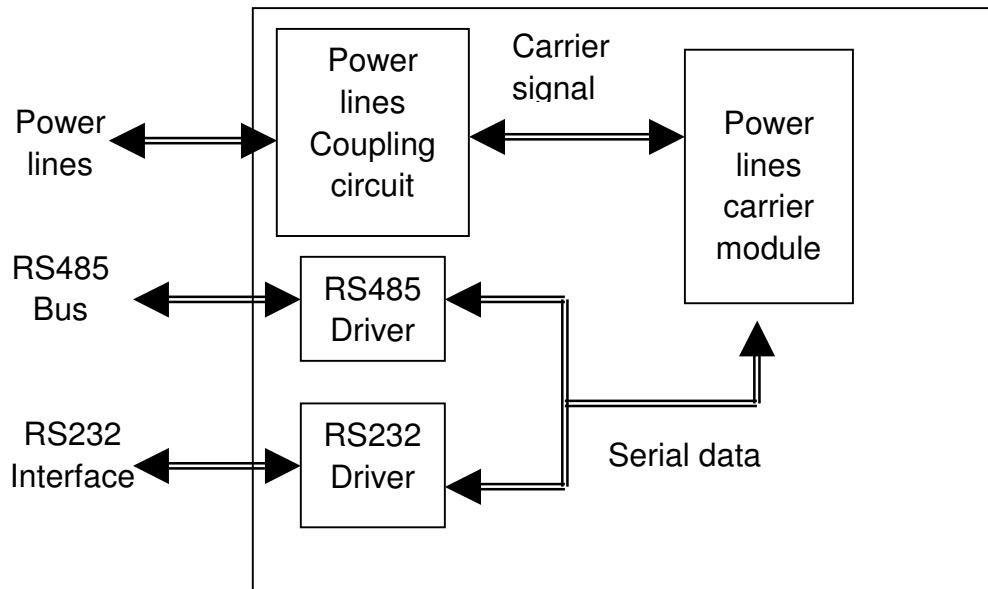

### 2 Board Layout

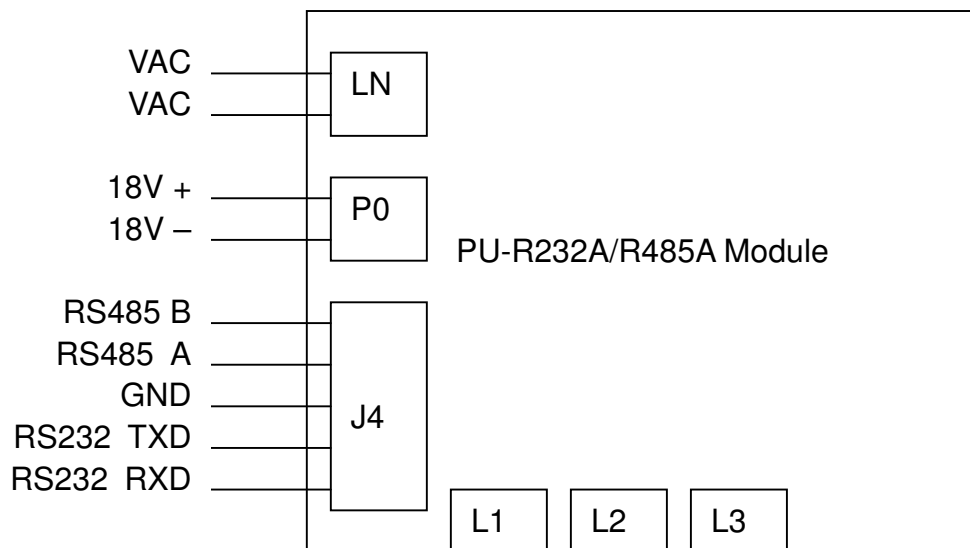

### 3 LED

L1	PLC LED: green means module is sending data to PLC; red means module is receiving data from PLC
L2	System LED, green means system is in normal
L3	Serial port LED, green means module is receiving data from aerial port; red means module is sending data to serial port

### 4 Definition of Pin

Power lines	1	VAC	220VAC/50Hz or 110VAC/60Hz
	2	VAC	220VAC/50Hz or 110VAC/60Hz
Module power	3	18V+	+18VDC
	4	18V-	-18VDC
RS485 bus	5	RS485 B	RS485busB
	6	RS485 A	RS485 bus A
GND	7	GND	GND
RS232 interface	8	RS232TXD	RS232 data transmission should link to PC's RXD
	9	RS232 RXD	RS232 data receiving should link to PC's RXD

## III Command Interface

### 1 Command Mode

#### 1.1 Enter command mode

The module can be put into command mode by sending “+++” through serial port. The module will respond with an “ok”. In order to prevent the situation where the user data “+++” mistakenly triggers the command mode, there must be no serial port data input one second before and after the receiving of “+++”. At the same time, the gap between the three “+” should not be more than one second, otherwise, it will be considered as a data rather than a command.

#### 1.2 Exit command mode

There are two approaches to exit command mode. One way is to input command “ATEX”. The other is to timeout and automatically exit. In either case, the modules will response "exited". The timeout value can be set by command "ATTO"

### 2 Arguments and Responses

#### 2.1 Arguments and Responses

For all the commands with arguments: if the parameters are correct, the module will respond with an “ok”. Otherwise, the modules will response with an “invalid para”. If there are no arguments associated with the commands, it will be treated as polling modem and the module will respond with the existing arguments residing in the module.

## 2.2 Commands without Arguments

There are four commands without arguments.

- + + +: enter command mode; will directly return “ok”.
- ATEX: exit the command mode, return “exited”.
- ATRS: software reset, will reset the module immediately, no return.
- ATSR: in search for other modules on the power lines, this will return the name of the found module. Please wait for two seconds after sending a command. The name of module received in two seconds will be shown in the serial port, otherwise, the name received after two seconds will be ignored. Note: In the course of searching, all bytes input from serial port also will also be ignored.

## 2.3 Modified arguments

Except for serial arguments, the modified arguments will be immediately saved into eeprom and take effect. The serial arguments won't take effect immediately after being modified to avoid user from modifying PC serial arguments before inputting command. Serial arguments will take effect through automatically resetting module when exiting the command mode.

### 3 Command List

Command	Description	Arguments	Description	Default
Control Class				
+++		none	Enter command mode	
ATEX	Exit	none	Exit command mode	
ATTO	Time out	1-30	Timeout value, unit: second	5
ATRS	Reset	none	Software reset	
Network class				
ATDA	Domain Address	1-32767	Domain Address of Logic Address	1
ATNA	Node Address	1-65535	Node Address of logical address	1

Function class				
ATRP	Repeater	Y,N	Relay function, Y is on, N for off	Y
ATNM	Name	A string with length less than 15	Set the name of the module	PU-R485A
Communication class				
ATBD	Baud Rate	1200, 2400, 4800, 9600, 19200	Baud Rate	9600
ATDB	Data Bit	5,6,7,8	Data bit	8
ATPA	Parity	N, O, E	Parity bit, N = no, O = odd, E = even	N
ATST	Stop Bit	1,2	Stop bit	1
Debug class				

ATRW	Raw	Y,N	The raw data for debugging. The module will output sent raw packets from host to the module, and not just the payload. Y means turn on this function, N means turning off.	N
ATMI	MIOpattern	Y,N	Support compatible issue with Ariane MIO-RS232 format. The header of the data package will be "A3 04".	N
ATSR	Search	none	Search for peer module on the power line network	

## IV Repeater Function

### 1 Introduction

To extend the coverage, LinkSprite modules have built-in repeater function.

When the module's repeater function is turned on (ON is the default setting), the module echos the data packet from the power line, while entertaining the data sent by host through the serial port.

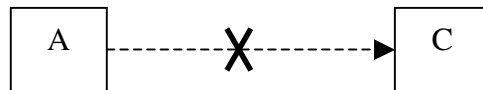

Because of far distance, data transmission can not be reached.

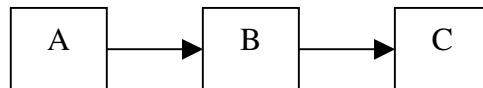

After adding repeater function to proper locations, the data can be transmitted farther.

Transceiver function is not influenced by repeater function, that is to say, each module can be used as a separate repeater or can be seen as repeater when sending and receiving data. It can not only send and receive data from the power line, but also repeat other data packets.

In order to prevent network congestion, the module is smart enough to know the data were sent or repeated by itself and will discard the data

packets when receiving the duplicated ones.

**Note:** Due to the fact that repeaters will resent the received data packets, if the number of repeater is too large, a number of repeaters will seize the channel, and lead to increased communication time. When deploying the repeater, one should take full account of the balance of reliability and real-time.

## 2 Function Setting

AT command 'ATRP' is designed to set up the repeater function.

### 2.1 Turn on repeater function

Steps	input	response	description
1	+++	ok	Enter command mode
2	ATRP	Y or N	Poll current repeater status, Y is on, N for off
3	ATRP Y	ok	Turn on repeater function
4	ATRP	Y	Check present repeat status, ON
5	ATEX	exit	Exit command mode

## 2.2 Turn off repeater function

steps	input	response	description
1	+++	ok	Enter command mode
2	ATRP	Y or N	Check current repeater status, Y is on, N for off
3	ATRP N	ok	Turn off repeater function
4	ATRP	N	Check current repeater status, OFF
5	ATEX	exit	Exit command mode

## 2.3 Setting Illustration

- Repeater function is available in the factory.
- Once repeater function is modified; it will immediately take effect and be preserved permanently, even if the module is restarted.

## 3 Repeater Hops

A data packet could at most pass through third repeater three times. It is shown as follows:

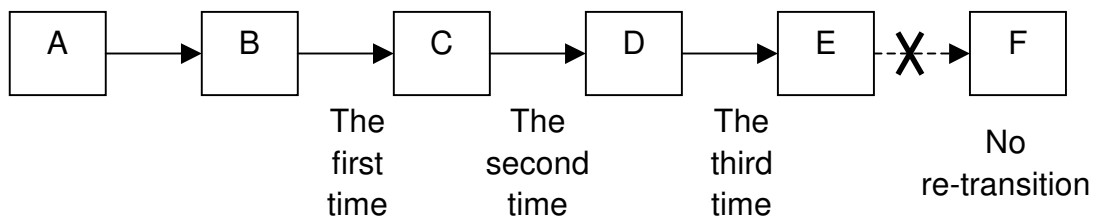

Data packet is sent from module A to module B. From module B to module C is the first time, to module D is the second time, and to module E is the third time. Module F is the termination. Therefore, data packet won't be sent to module F.

# V Logic Address

## 1 Logic Address

Module data packets are transmitted in the way of broadcasting in power lines. All modules will receive the data packets issued by the module and sent them, through the serial port under carrier signals area.

When multiple modules are installed on the same power line network, however, one does not want them to communicate directly; thus, the networks can be addressed by the logic address.

Logic address is composed of two parts: domain and nodes. For example, the logic address (10:200) means that the domain value is 10, node value is 200. Logic address is the default setting (1:1).

Module data packets can only be received and processed by the module at the same domain. Other modules, even detecting the carrier signal will not receive, nor to transmit to the serial port or repeater.

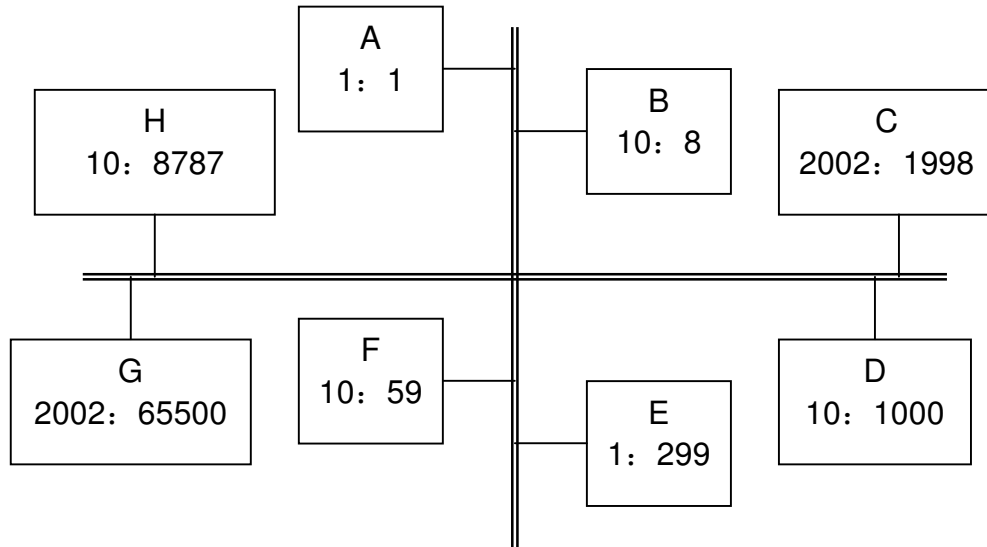

On the above figure, A, E are at the same network, their domain values are 1; B, D, F, H are at the same network, its domain values are 10; C, G are at the same network, their domain values are 2002. Although in the physically speaking, all the modules are in a power line network, the packet issued by A, will only be received and processed by E, other modules will not respond. Similarly, packet issued by F, only B, D, H will receive and process packet issued by F, other modules will not work.

## 2 Address Setting

step	input	response	description
1	+++	ok	Enter command mode
2	ATDA	1-32767	Check domain values of present logic address. Default factory setting is 1.
3	ATNA	1-65535	Check nodes values of present logic address. Default factory setting is 1.
4	ATDA 2	ok	Set domain value of logic address as 2

5	ATNA 45	ok	Set nodes of logic address as 45
6	ATDA	2	Check domain values of logic address
7	ATNA	45	Check node values of logic address
8	ATEX	exited	Exit command mode

## VI Application Illustration

Intelligent instruments widely adopt RS485 bus to communicate. For example, the power meter automatic meter reading systems, data concentrator through the RS485 bus read the message from power meter.

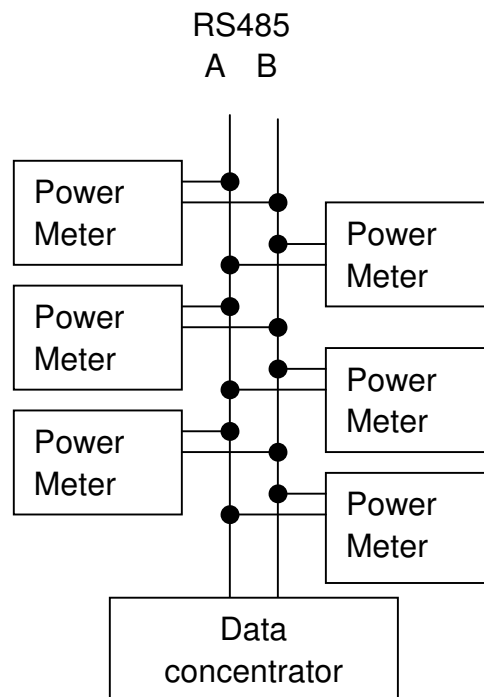

In order to automatically meter reading, RS485 bus needs to be deployed. Here, using PU-R485A module, one can use the existed power lines to directly complete data transmission.

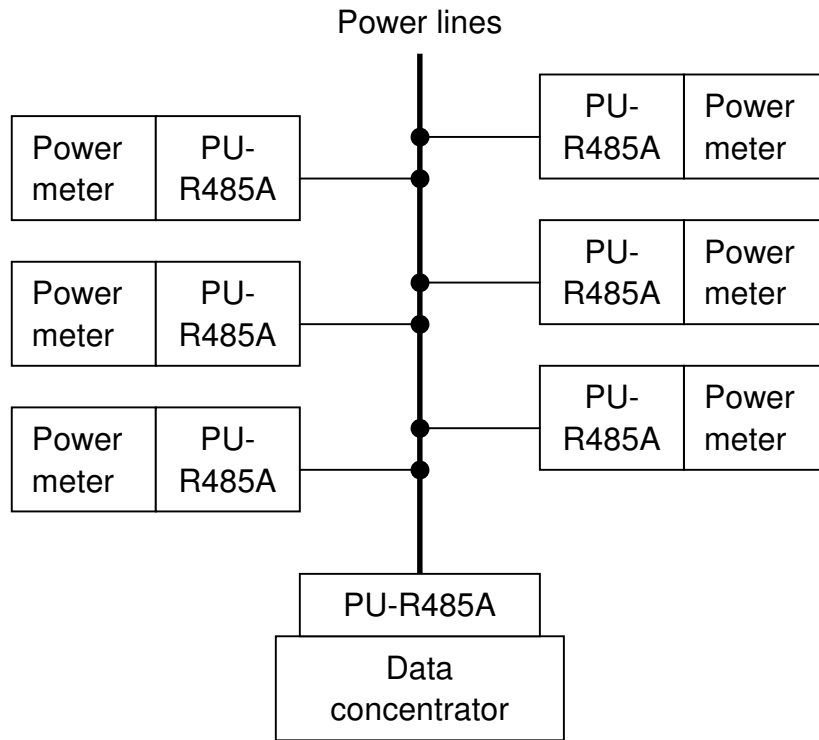

LinkSprite Technologies, Inc.  
1410 Cannon Mountain Dr.  
Longmont, CO 80503  
(Voice) 720-949-4-932  
(Email) [sales@linksprite.com](mailto:sales@linksprite.com)  
<http://www.linksprite.com>

